

Thyristor T453-1250-18



Mean on-state current		I_{TAV}		1250 A				
Repetitive peak off-state voltage		V_{DRM}		1000 - 1800 V				
Repetitive peak reverse voltage		V_{RRM}						
Turn-off time		t_q		160, 200, 250, 320, 400, 500 μ s				
V_{DRM}, V_{RRM}, V	1000	1100	1200	1300	1400	1500	1600	1800
Voltage code	10	11	12	13	14	15	16	18
$T_j, ^\circ C$	-60 ÷ 125							

MAXIMUM ALLOWABLE RATINGS

Symbols and parameters		Units	Values	Test conditions	
ON-STATE					
I_{TAV}	Mean on-state current	A	1250 1385	$T_c=90^\circ C$, Double side cooled $T_c=85^\circ C$, Double side cooled 180° half-sine wave; 50 Hz	
I_{TRMS}	RMS on-state current	A	1962	$T_c=90^\circ C$, Double side cooled 180° half-sine wave; 50 Hz	
I_{TSM}	Surge on-state current	kA	29.0 33.0	$T_j=T_{jmax}$ $T_j=25^\circ C$	180° half-sine wave; $t_p=10$ ms; single pulse; $V_D=V_R=0$ V; Gate pulse: $I_G=2$ A; $t_{GP}=50$ ms; $di_G/dt \geq 1$ A/ms
			30.0 35.0	$T_j=T_{jmax}$ $T_j=25^\circ C$	180° half-sine wave; $t_p=8.3$ ms; single pulse; $V_D=V_R=0$ V; Gate pulse: $I_G=2$ A; $t_{GP}=50$ ms; $di_G/dt \geq 1$ A/ms
I^2t	Safety factor	$A^2s \cdot 10^3$	4200 5400	$T_j=T_{jmax}$ $T_j=25^\circ C$	180° half-sine wave; $t_p=10$ ms; single pulse; $V_D=V_R=0$ V; Gate pulse: $I_G=2$ A; $t_{GP}=50$ ms; $di_G/dt \geq 1$ A/ms
			3700 5000	$T_j=T_{jmax}$ $T_j=25^\circ C$	180° half-sine wave; $t_p=8.3$ ms; single pulse; $V_D=V_R=0$ V; Gate pulse: $I_G=2$ A; $t_{GP}=50$ ms; $di_G/dt \geq 1$ A/ms
BLOCKING					
V_{DRM}, V_{RRM}	Repetitive peak off-state and Repetitive peak reverse voltages	V	1000 - 1800	$T_{jmin} < T_j < T_{jmax}$; 180° half-sine wave; 50 Hz; Gate open	
V_{DSM}, V_{RSM}	Non-repetitive peak off-state and Non-repetitive peak reverse voltages	V	1100 - 1900	$T_{jmin} < T_j < T_{jmax}$; 180° half-sine wave; single pulse; Gate open	
V_D, V_R	Direct off-state and Direct reverse voltages	V	$0.6 \cdot V_{DRM}$ $0.6 \cdot V_{RRM}$	$T_j=T_{jmax}$; Gate open	

TRIGGERING				
I_{FGM}	Peak forward gate current	A	8	$T_j = T_{j\max}$
V_{RGM}	Peak reverse gate voltage	V	5	
P_G	Gate power dissipation	W	4	$T_j = T_{j\max}$ for DC gate current
SWITCHING				
$(di_T/dt)_{crit}$	Critical rate of rise of on-state current non-repetitive (f=1 Hz)	A/ms	1250	$T_j = T_{j\max}$; $V_D = 0.67 \cdot V_{DRM}$; $I_{TM} = 5400$ A; Gate pulse: $I_G = 2$ A; $t_{GP} = 50$ ms; $di_G/dt \geq 2$ A/ms
THERMAL				
T_{stg}	Storage temperature	°C	-60...50	
T_j	Operating junction temperature	°C	-60...125	
MECHANICAL				
F	Mounting force	kN	24.0...28.0	
a	Acceleration	m/s ²	50	Device clamped

CHARACTERISTICS

Symbols and parameters		Units	Values	Conditions	
ON-STATE					
V_{TM}	Peak on-state voltage, max	V	1.70	$T_j = 25$ °C; $I_{TM} = 3925$ A	
$V_{T(TO)}$	On-state threshold voltage, max	V	0.998	$T_j = T_{j\max}$;	
r_T	On-state slope resistance, max	mW	0.179	$0.5 \text{ p } I_{TAV} < I_T < 1.5 \text{ p } I_{TAV}$	
I_L	Latching current, max	mA	1500	$T_j = 25$ °C; $V_D = 12$ V; Gate pulse: $I_G = 2$ A; $t_{GP} = 50$ ms; $di_G/dt \geq 1$ A/ms	
I_H	Holding current, max	mA	300	$T_j = 25$ °C; $V_D = 12$ V; Gate open	
BLOCKING					
I_{DRM}, I_{RRM}	Repetitive peak off-state and Repetitive peak reverse currents, max	mA	150	$T_j = T_{j\max}$; $V_D = V_{DRM}$; $V_R = V_{RRM}$	
$(dv_D/dt)_{crit}$	Critical rate of rise of off-state voltage ¹⁾ , min	V/ms	200, 320, 500, 1000, 1600, 2000, 2500	$T_j = T_{j\max}$; $V_D = 0.67 \cdot V_{DRM}$; Gate open	
TRIGGERING					
V_{GT}	Gate trigger direct voltage, max	V	3.00 2.50 1.50	$T_j = T_{j\min}$ $T_j = 25$ °C $T_j = T_{j\max}$	$V_D = 12$ V; $I_D = 3$ A; Direct gate current
I_{GT}	Gate trigger direct current, max	mA	500 300 150	$T_j = T_{j\min}$ $T_j = 25$ °C $T_j = T_{j\max}$	
V_{GD}	Gate non-trigger direct voltage, min	V	0.40	$T_j = T_{j\max}$;	
I_{GD}	Gate non-trigger direct current, min	mA	55.00	$V_D = 0.67 \cdot V_{DRM}$; Direct gate current	
SWITCHING					
t_{gd}	Delay time, max	ms	1.10	$T_j = 25$ °C; $V_D = 1000$ V; $I_{TM} = I_{TAV}$; $di/dt = 200$ A/ms;	
t_{gt}	Turn-on time, max	ms	3.00	Gate pulse: $I_G = 2$ A; $V_G = 20$ V; $t_{GP} = 50$ ms; $di_G/dt = 2$ A/ms	
t_q	Turn-off time ²⁾ , max	ms	160, 200, 250, 320, 400, 500	$dv_D/dt = 50$ V/ms; $T_j = T_{j\max}$; $I_{TM} = I_{TAV}$; $di_R/dt = -10$ A/ms; $V_R = 100$ V; $V_D = 0.67 \cdot V_{DRM}$	
Q_{rr}	Total recovered charge, max	mC	2700	$T_j = T_{j\max}$; $I_{TM} = 2000$ A; $di_R/dt = -10$ A/ms; $V_R = 100$ V;	
t_{rr}	Reverse recovery time, max	ms	30		
I_{rrM}	Peak reverse recovery current, max	A	180		

THERMAL					
R_{thjc}	Thermal resistance, junction to case, max	°C/W	0.0180	Direct current	Double side cooled
R_{thjc-A}			0.0396		Anode side cooled
R_{thjc-K}			0.0324		Cathode side cooled
R_{thck}	Thermal resistance, case to heatsink, max	°C/W	0.0040	Direct current	
MECHANICAL					
w	Weight, max	g	550		
D_s	Surface creepage distance	mm (inch)	31.60 (1.244)		
D_a	Air strike distance	mm (inch)	16.50 (0.649)		

OVERALL DIMENSIONS

Package type: PT53

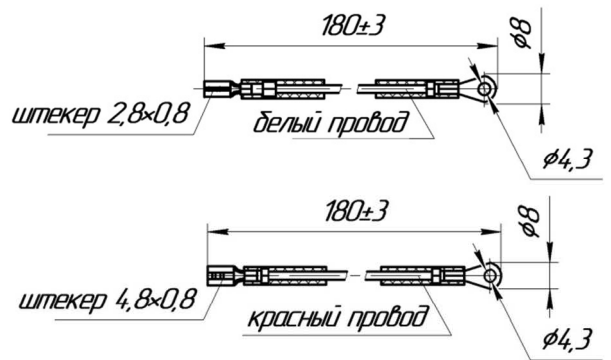
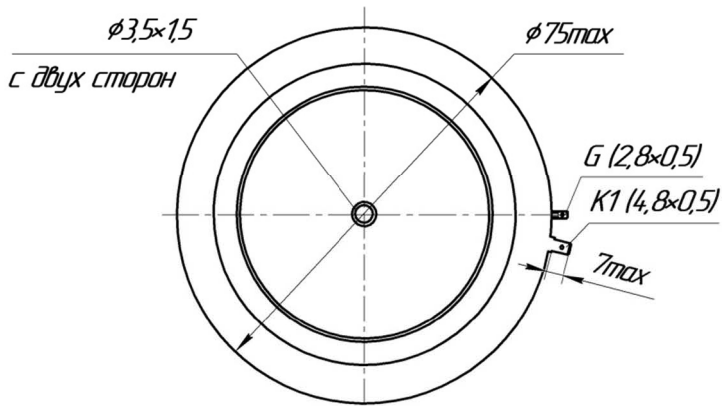
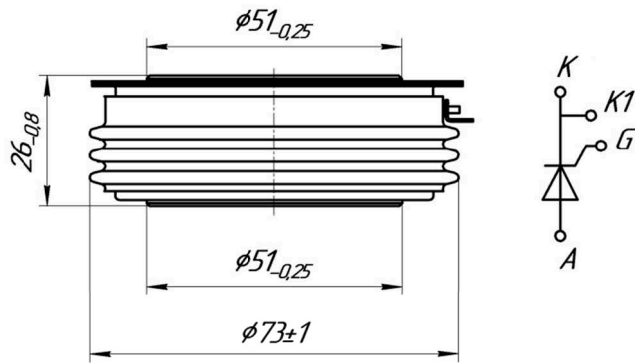

- K – cathode;
- A – anode;
- K1 – auxiliary cathode;
- G – gate;

All dimensions in millimeters

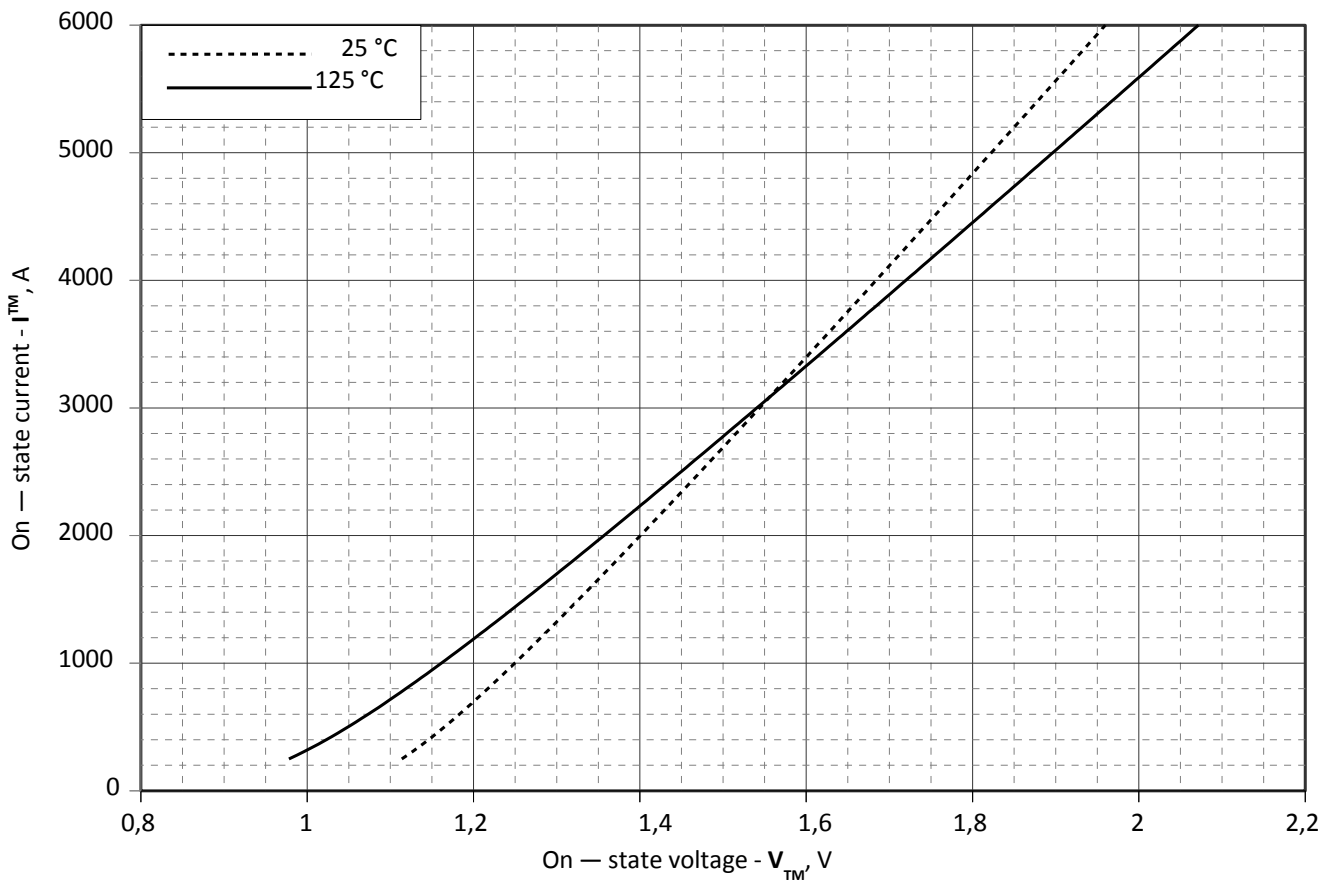

Fig 1 – On-state characteristics of Limit device

Analytical function for On-state characteristic:

$$V_T = A + B \cdot i_T + C \cdot \ln(i_T + 1) + D \cdot \sqrt{i_T}$$

	Coefficients for max curves	
	$T_j = 25^\circ\text{C}$	$T_j = T_{j\text{max}}$
A	0.93969000	0.69309000
B	0.00013164	0.00016967
C	0.02509500	0.04508000
D	0.00015368	-0.00040906

On-state characteristic model (see Fig. 1)

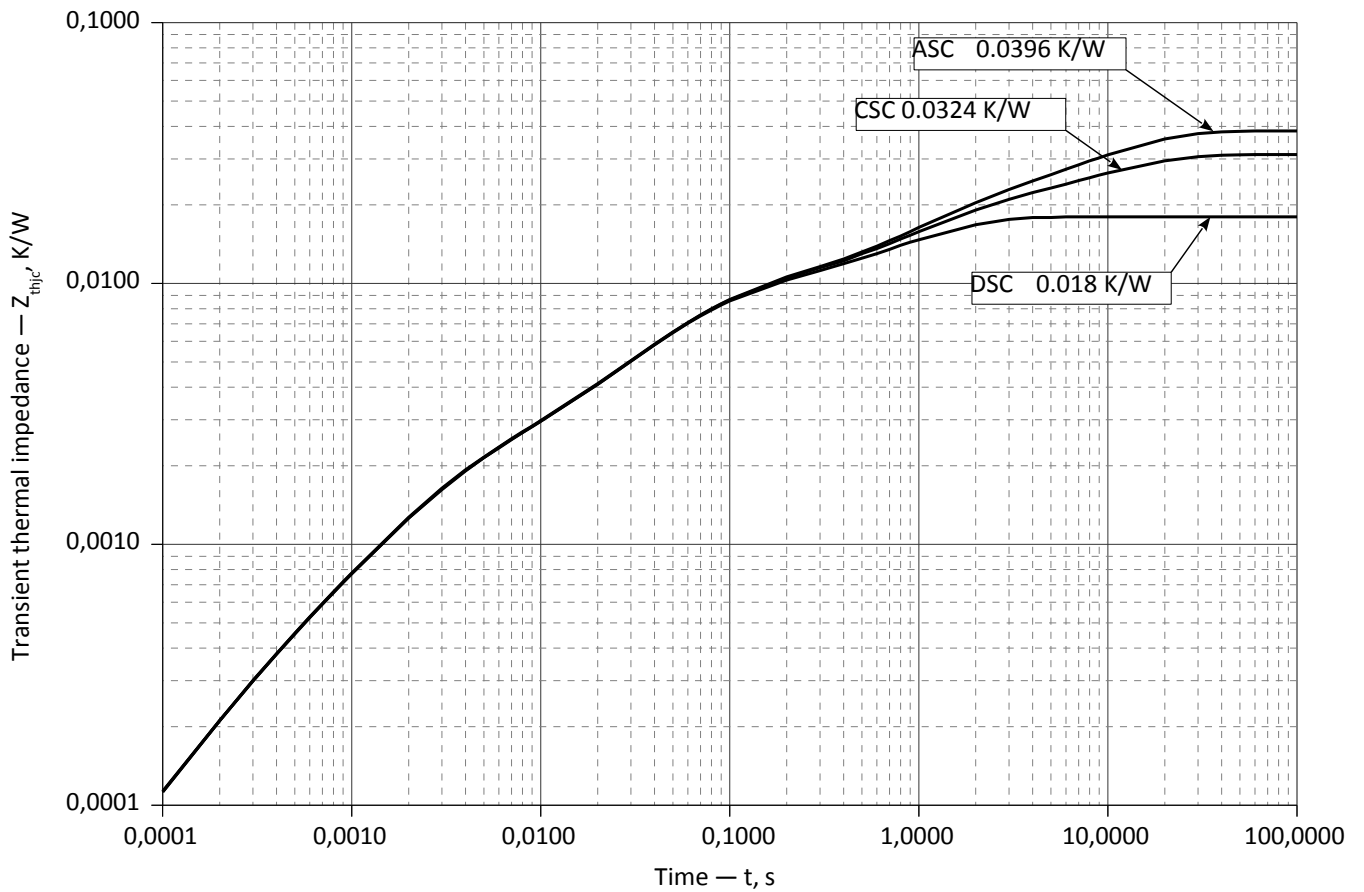

Fig 2 – Transient thermal impedance Z_{thjc} vs. time t

Analytical function for Transient thermal impedance junction to case Z_{thjc} for DC:

$$Z_{thjc} = \sum_{i=1}^n R_i \left(1 - e^{-\frac{t}{\tau_i}} \right)$$

Where $i = 1$ to n , n is the number of terms in the series.

t = Duration of heating pulse in seconds. Z_{thjc}

= Thermal resistance at time t .

R_i = Amplitude of p_{th} term.

τ_i = Time constant of r_{th} term.

DC Double side cooled

i	1	2	3	4	5	6
R_i , K/W	0.009241	0.006037	0.001231	0.001054	0.0003396	0.00009575
τ_i , s	0.9673	0.04967	0.002733	0.07734	0.001638	0.0002248

DC Anode side cooled

i	1	2	3	4	5	6
R_i , K/W	0.01318	0.009281	0.006055	0.001018	0.001535	0.0001182
τ_i , s	9.745	1.028	0.05591	0.03732	0.002468	0.0002687

DC Cathode side cooled

i	1	2	3	4	5	6
R_i , K/W	0.02041	0.009325	0.006949	0.0001252	0.001516	0.0001119
τ_i , s	9.752	1.065	0.05344	0.01407	0.002421	0.0002554

Transient thermal impedance junction to case Z_{thjc} model (see Fig. 2)

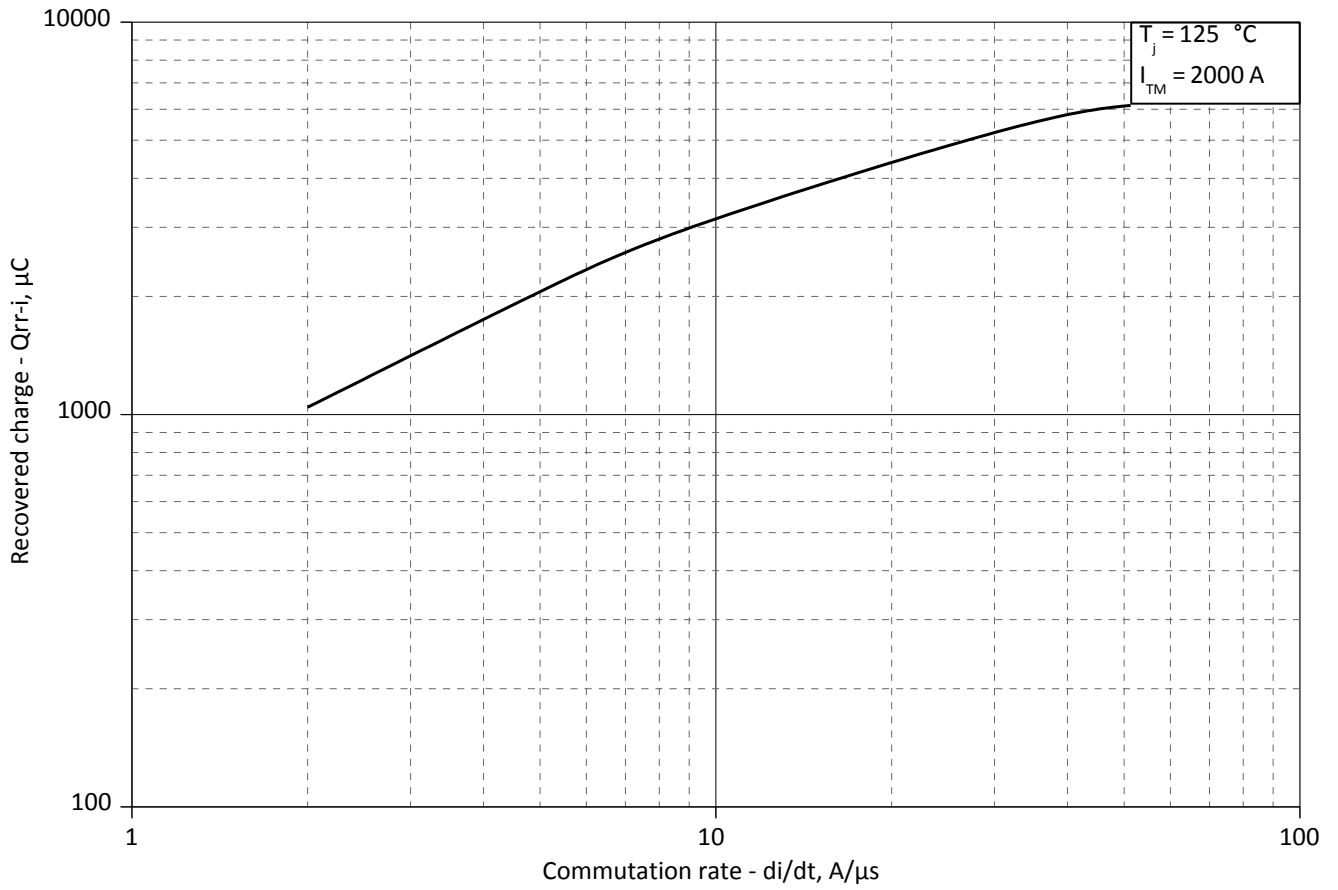

Fig 3 – Maximum recovered charge Q_{rr-i} (integral) vs. commutation rate di_r/dt

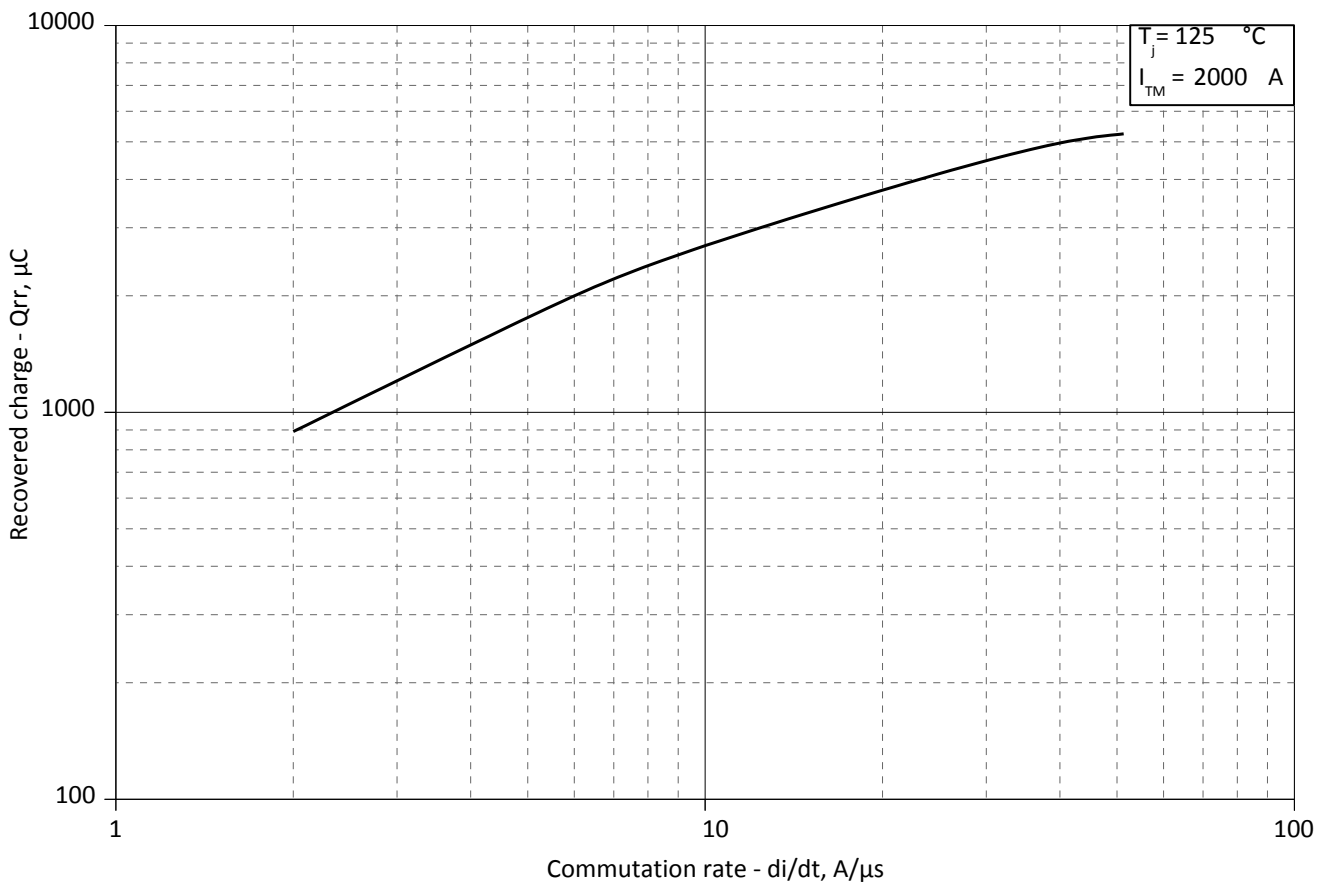

Fig 4 – Maximum recovered charge Q_{rr} vs. commutation rate di_r/dt (25% chord)

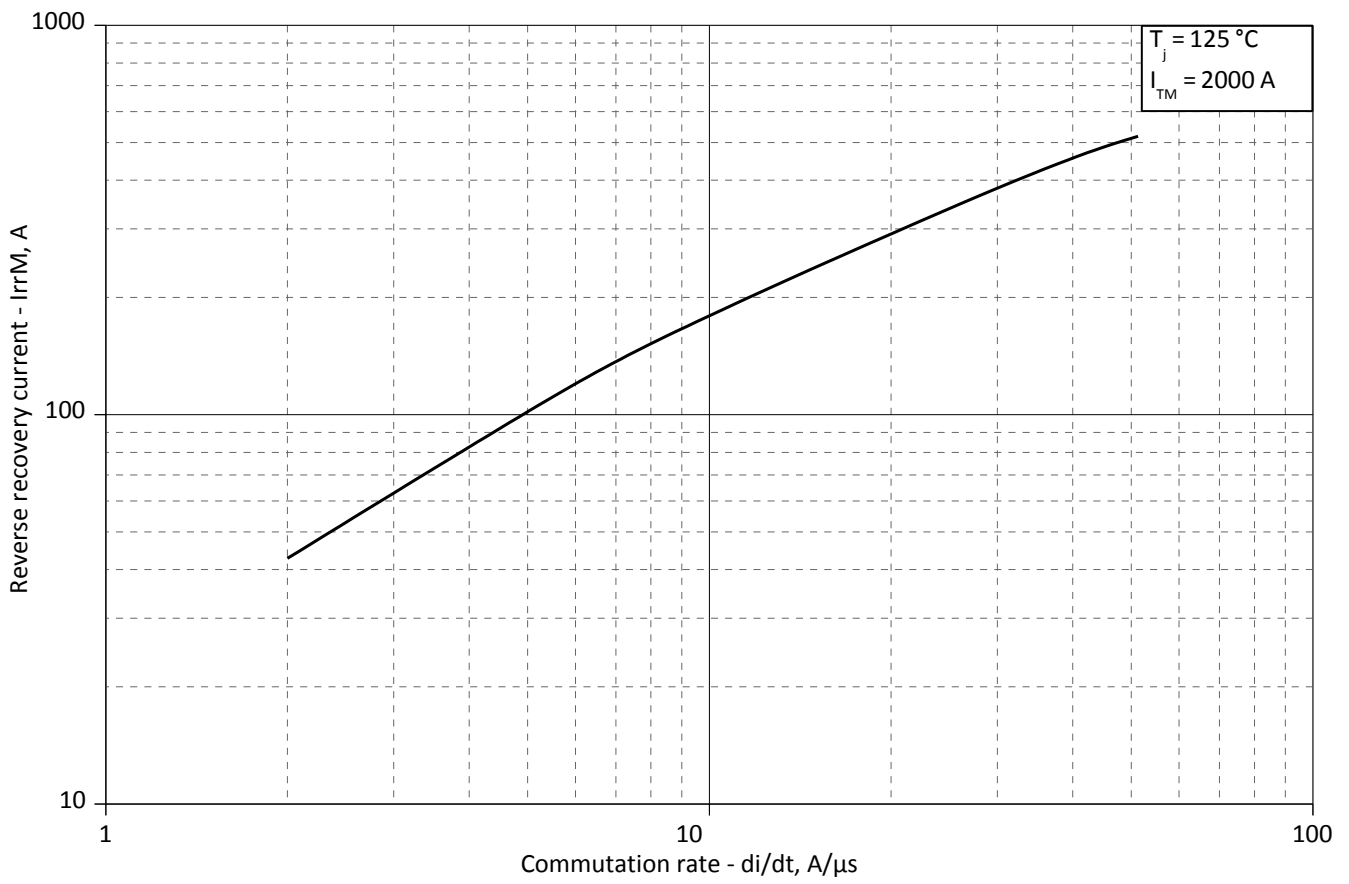

Fig 5 – Maximum reverse recovery current I_{rM} vs. commutation rate di_r/dt

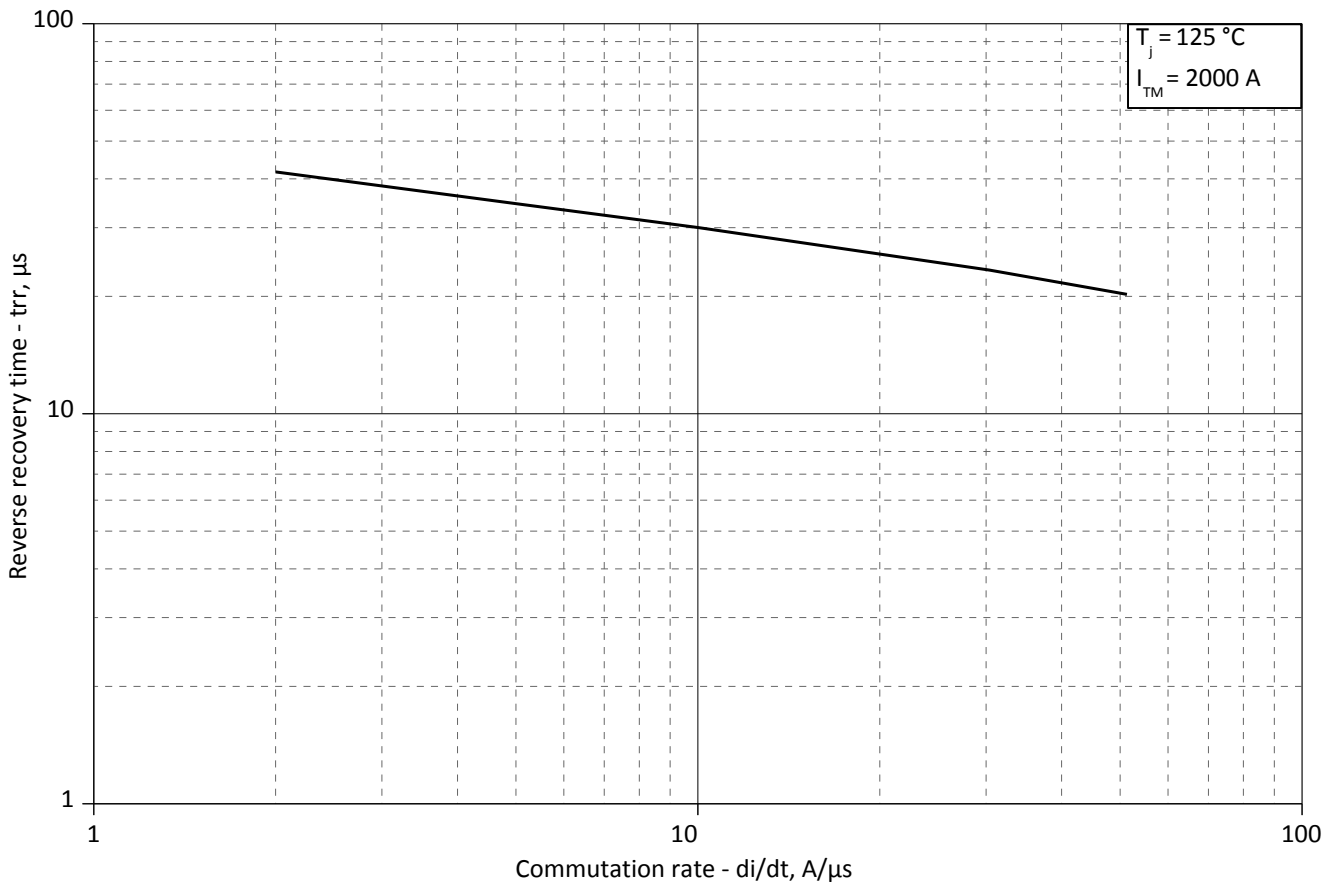

Fig 6 – Maximum recovery time t_r vs. commutation rate di_r/dt (25% chord)

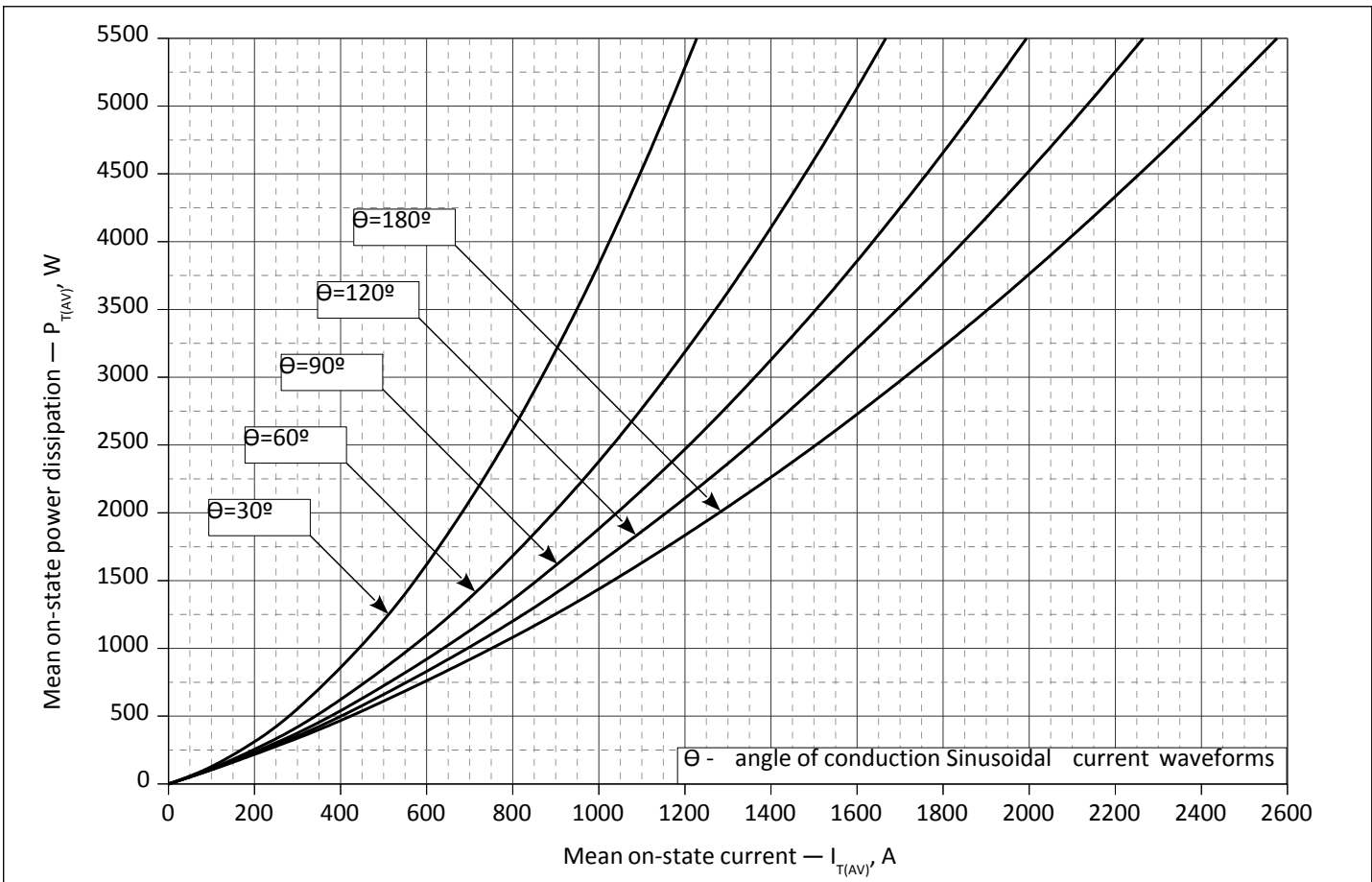

Fig. 7 - Mean on-state power dissipation P_{TAV} vs. mean on-state current I_{TAV} for sinusoidal current waveforms at different conduction angles ($f=50\text{Hz}$, DSC)

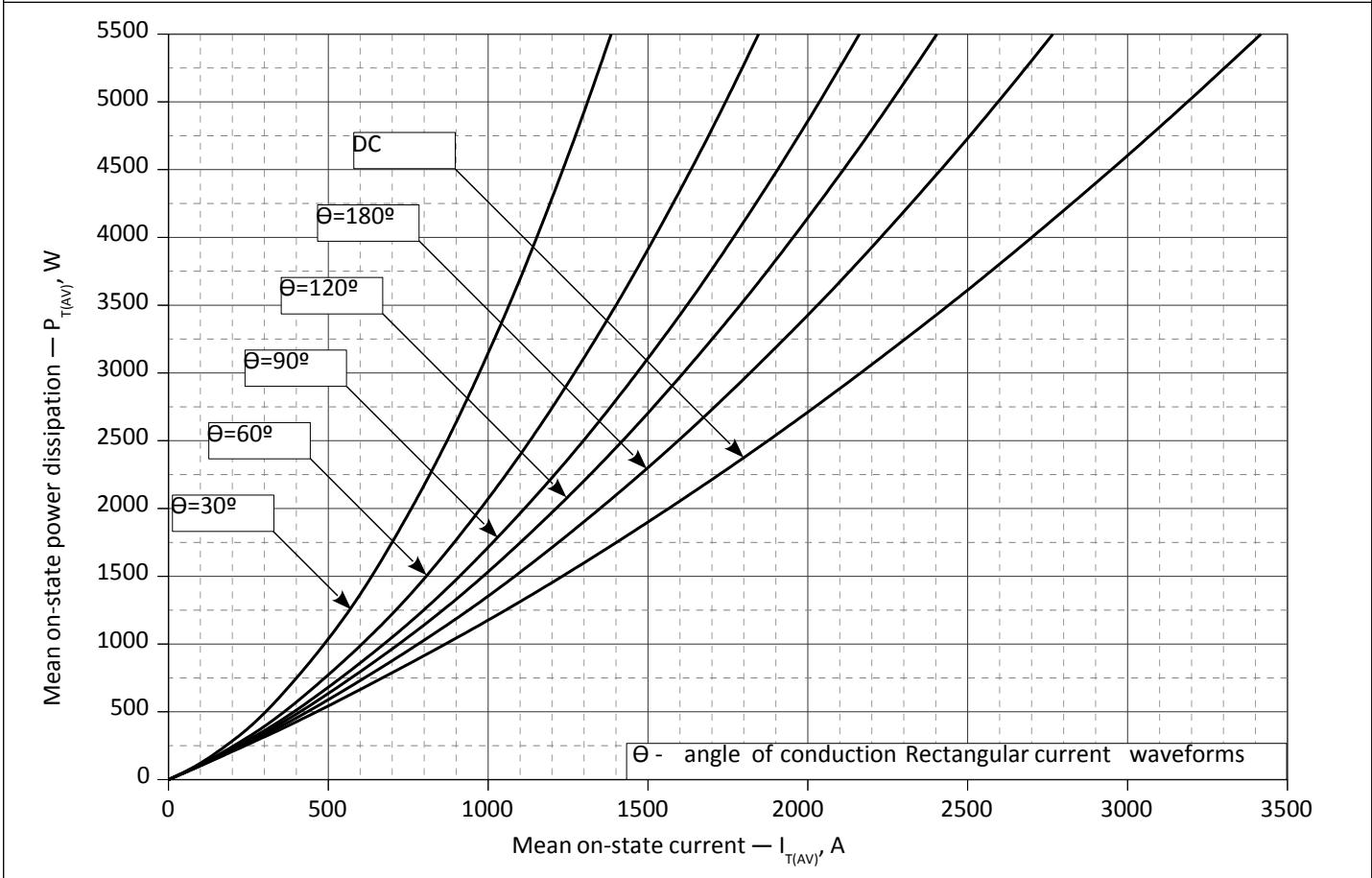

Fig. 8 - Mean on-state power dissipation P_{TAV} vs. mean on-state current I_{TAV} for rectangular current waveforms at different conduction angles and for DC ($f=50\text{Hz}$, DSC)

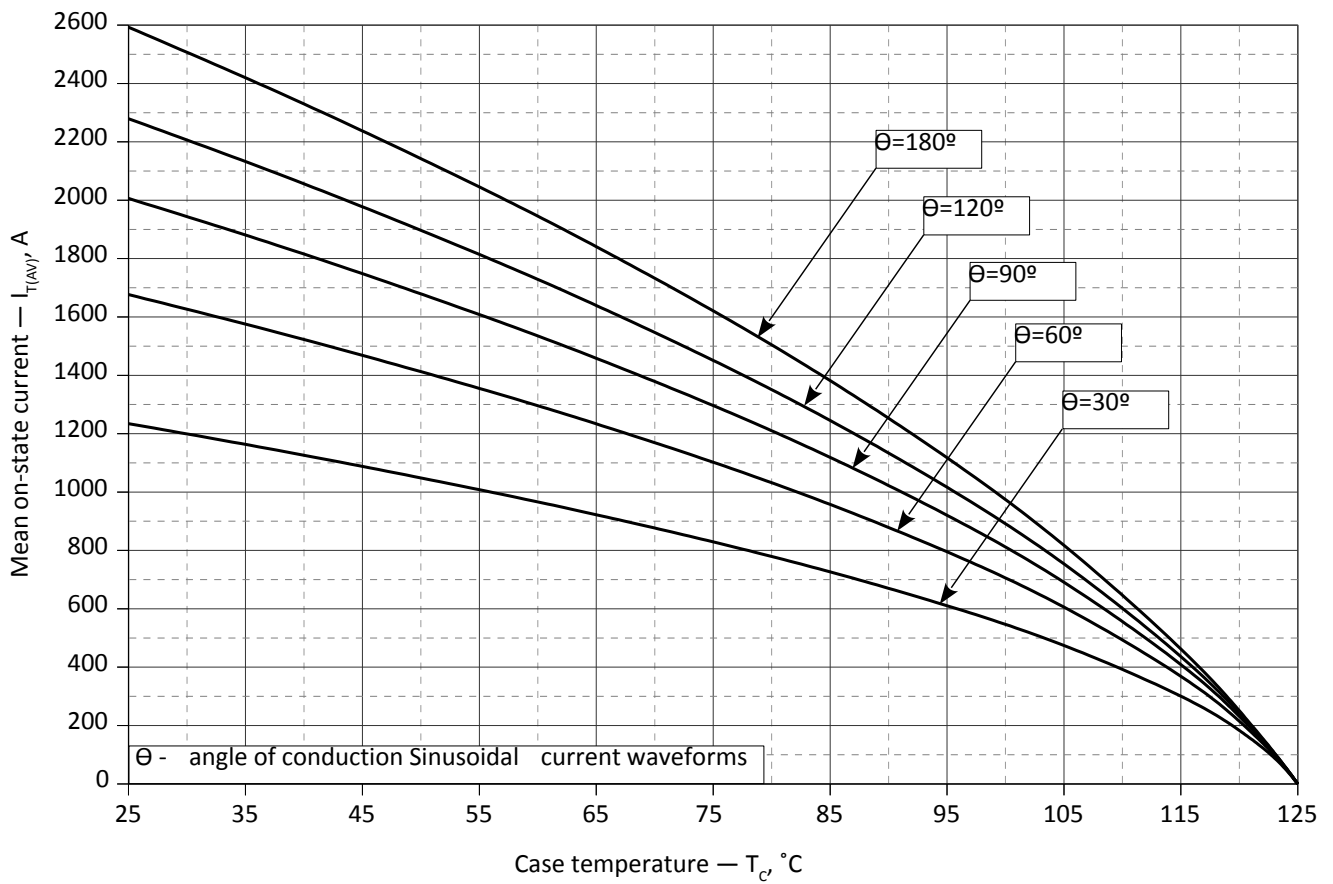

Fig. 9 – Mean on-state current $I_{T(AV)}$ vs. case temperature T_c for sinusoidal current waveforms at different conduction angles (f=50Hz, DSC)

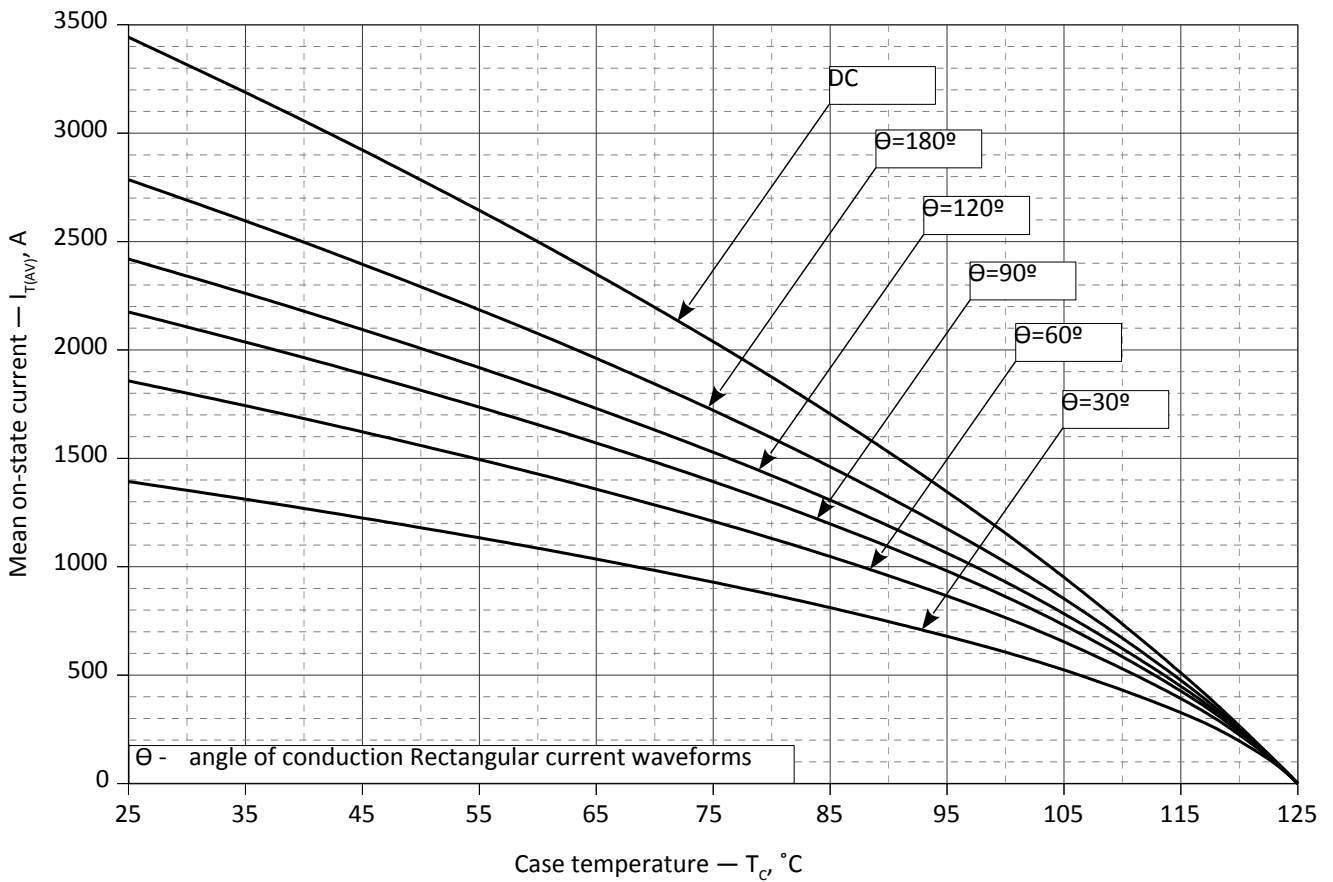

Fig. 10 - Mean on-state current $I_{T(AV)}$ vs. case temperature T_c for rectangular current waveforms at different conduction angles and for DC (f=50Hz, DSC)

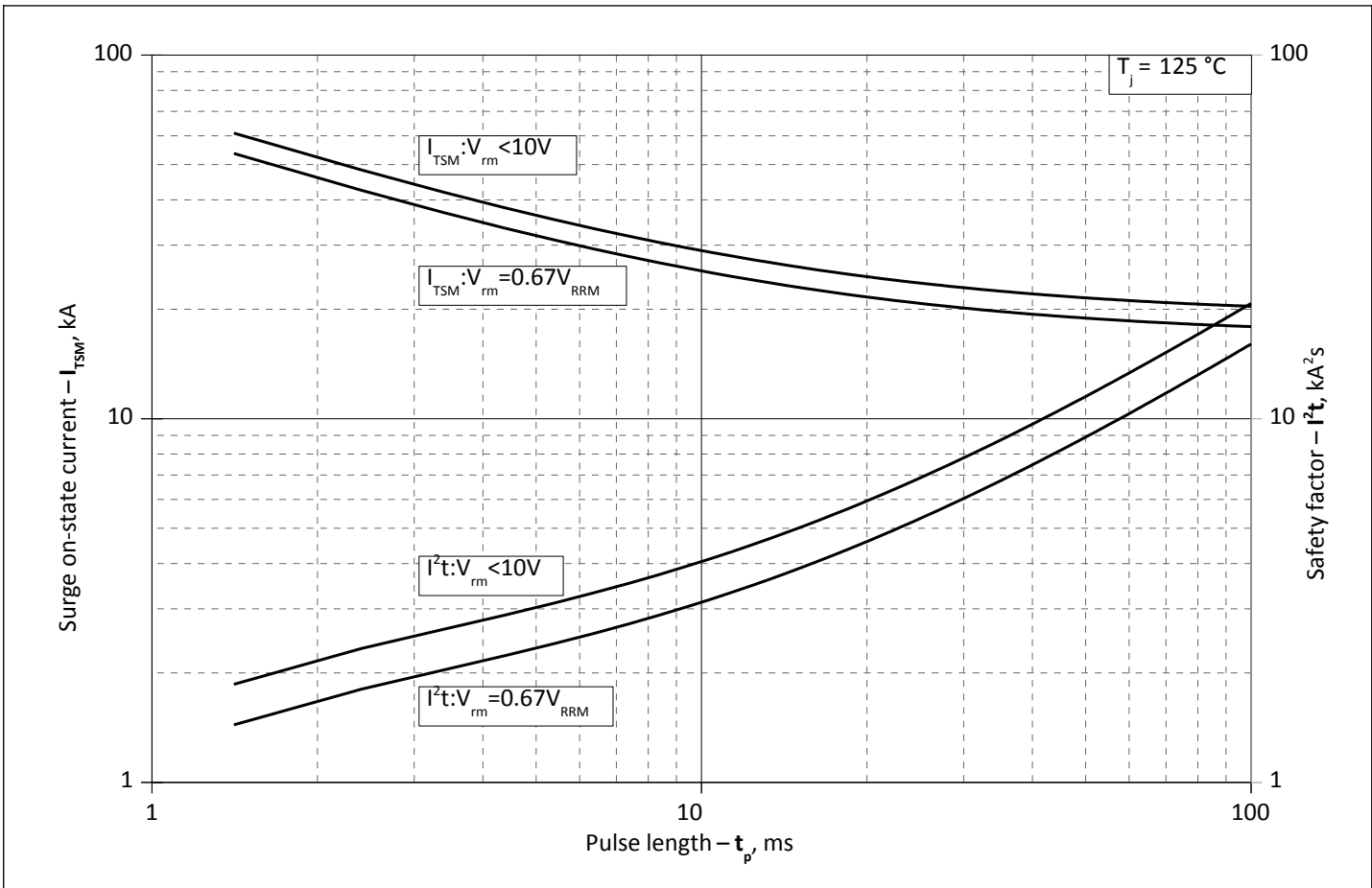

Fig. 11 – Maximum surge on-state current I_{TSM} and safety factor I^2t vs. pulse length t_p

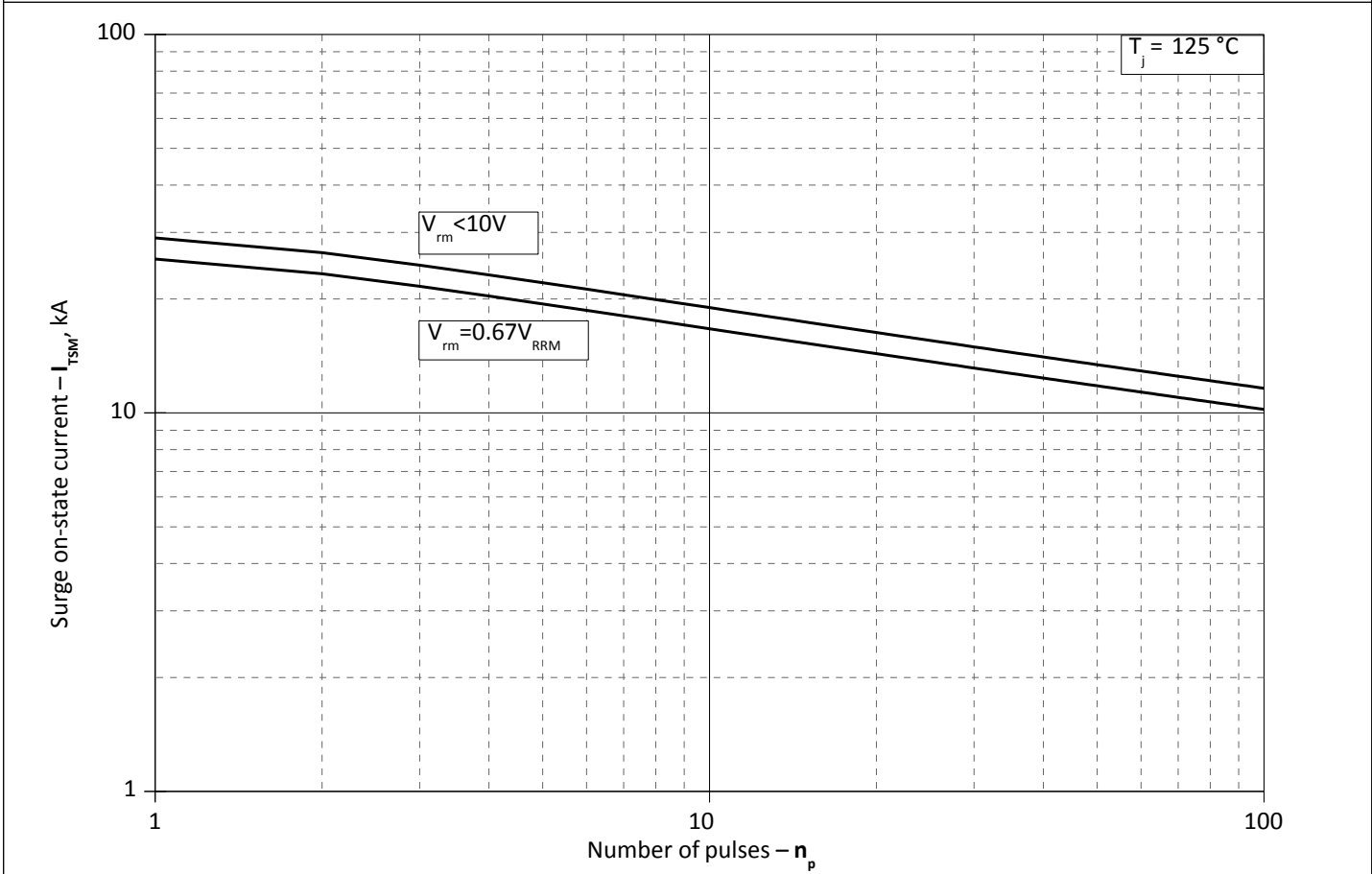

Fig. 12 - Maximum surge on-state current I_{TSM} vs. number of pulses n_p